

RACKS & SHELVINGS

INTRALOGISTICS AND SUPPLY CHAIN



RACKS & SHELVINGS

PIBRA'S Racks & Shelvings are developed by our engineering teams who create prototypes for all types of structures according with our client's needs and specifications.

Our teams are highly specialized and have a wide knowledge regarding how to approach and search for solutions, which allows us to better adapt to different concepts and demands of a project, and to respond to all requests.

We observe all safety procedures and use duly approved and certified materials, therefore ensuring the quality of our equipment and our client's full satisfaction.

INDEX

RACKS & SHELVINGS

RACKS	6
SHELVINGS	12



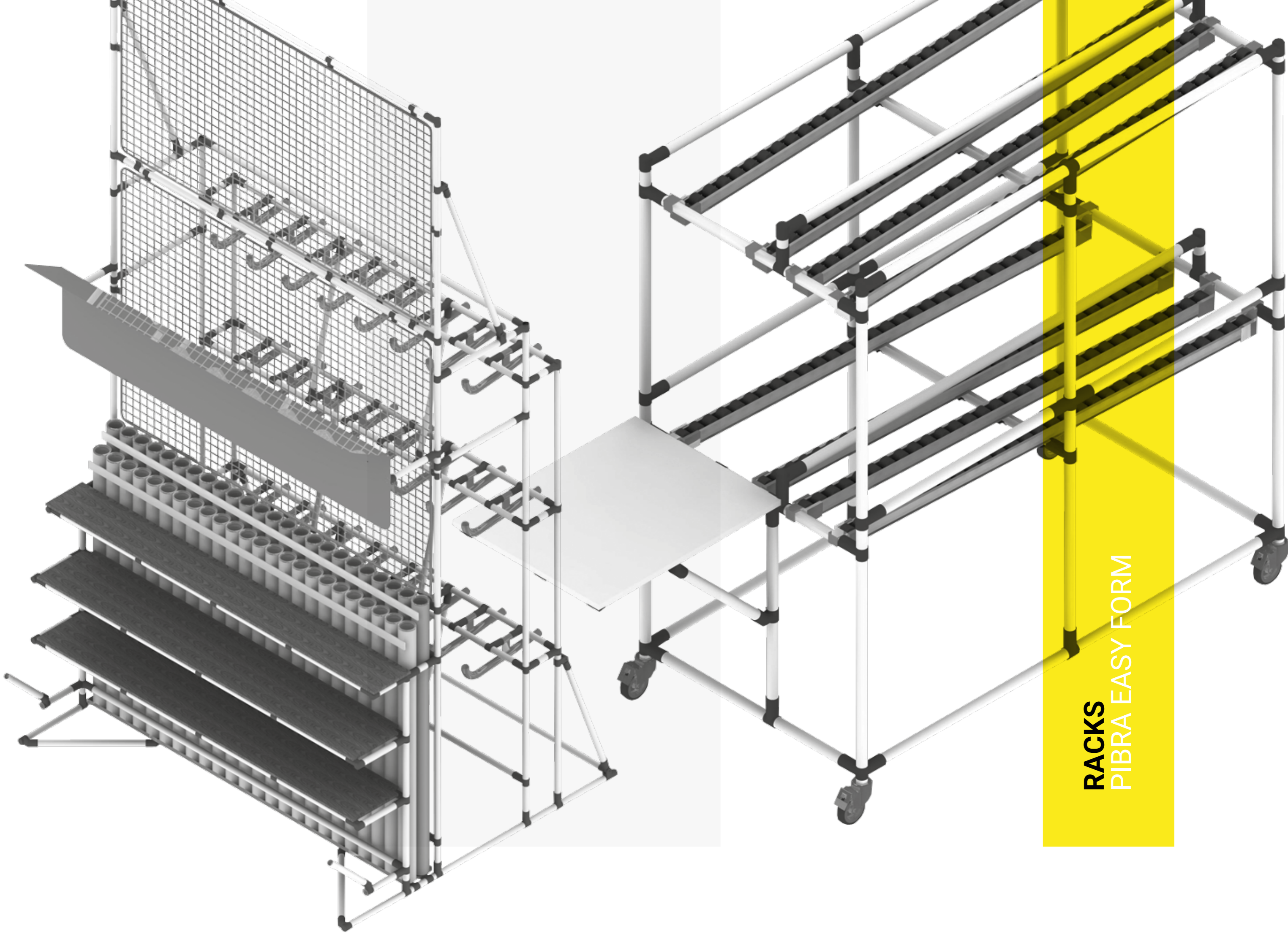

RACKS
PIBRA EASY FORM

DYNAMIC PALLET RACK

The **dynamic pallet** rack is a self-levelling structure with a void container disposal system for component storage on pallets. This equipment has a dynamic tray for empty boxes, or boxes on hold in the higher structure.

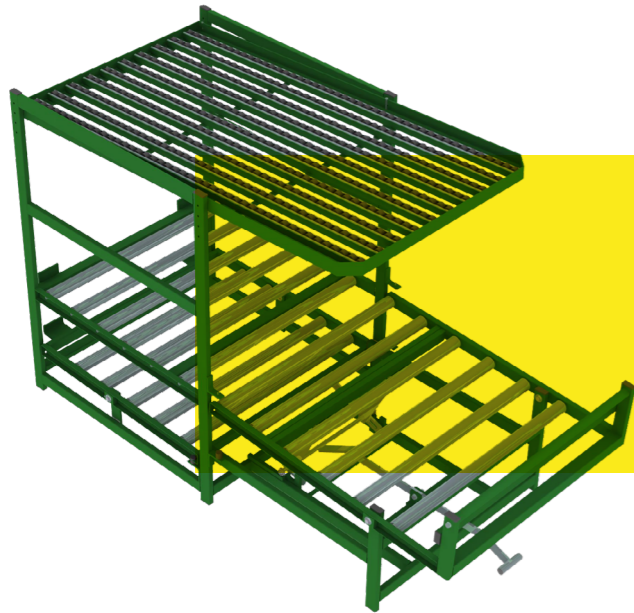

Advantages

- Flawless pallet rotation (**FIFO system - First In, First Out**).
- Saving time and space in pallet handling.
- Elimination of interferences in order preparation.
- Outstanding stock control.



PAINT

Structure painted with epoxy paint as per client specifications.

GENERAL DIMENSIONS
According to client specifications.

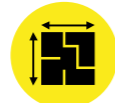

RAIL WITH ROLLERS

Metallic Rollers D.60mm (other dimensions).
Metallic rails with rollers.

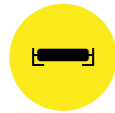

SPECIFIC COMPONENTS

Please refer to manufacturer for different configurations, dimensions and component quantities.



ADJUSTMENT BASES

Leg adjusters in order to ensure flawless ground fitting.



WELDED BUILD
Steel pipe welding.



DYNAMIC PALLET RACK

The **dynamic pallet** rack is a self-levelling structure with a void container disposal system for component storage on pallets. This equipment has a dynamic tray for empty boxes, or boxes on hold in the higher structure.

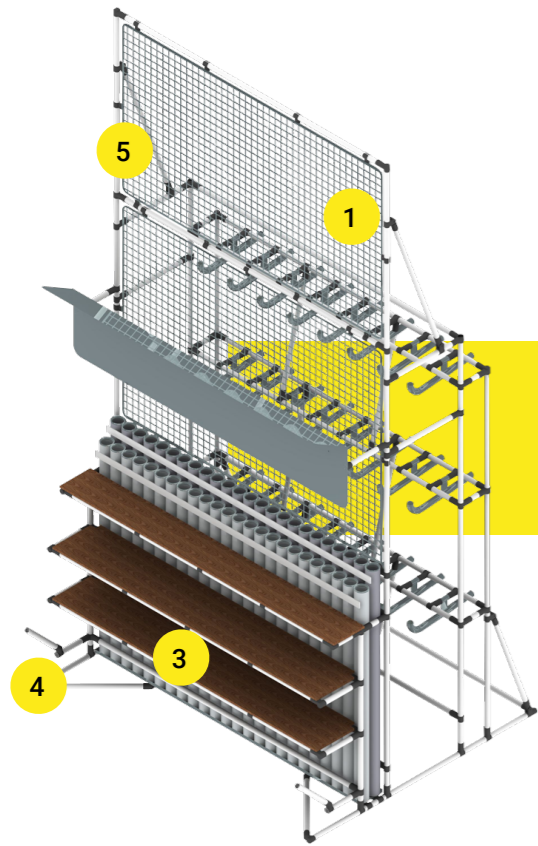

1 | PROTECTION

Metallic grid.

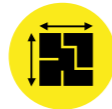

3 | RACKS AND SUPPLY

Wooden racks and pagoda-type supply in zinc-coated iron pipe.



5 | BUILD

Tubular profiles and fixation accessories as per the Lean modular philosophy (for more information, please refer to the PIBRA® catalogue).

GENERAL DIMENSIONS

According to client specifications.



4 | SPECIFIC COMPONENTS

Please refer to manufacturer for different configurations, dimensions and component quantities.



BOX RACK

The **box rack** is a structure to supply working areas with components that come in boxes, based on the **FIFO (First In, First Out)** methodology and correspondent return of empty boxes. There is also a tray to execute small preparations or assembly operations.

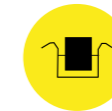
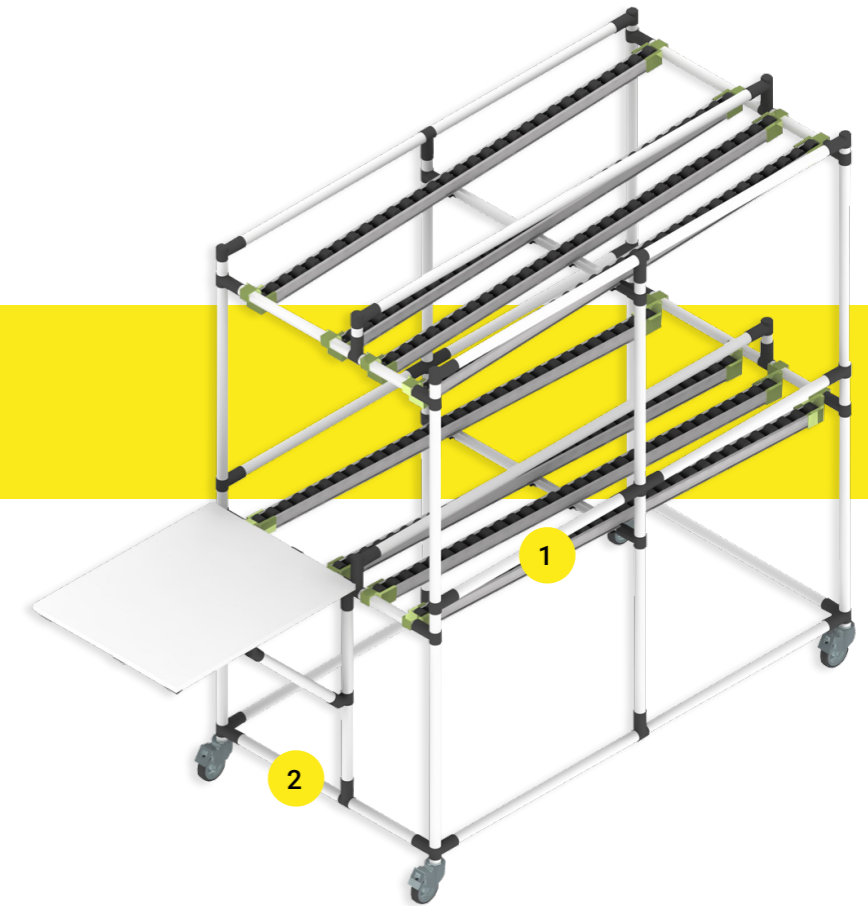

1 | RAIL WITH WHEELS

Rail with plastic wheels for box sliding.



GENERAL DIMENSIONS

According to client specifications.



BOX TYPE

DIMENSIONS 0.6 x 0.4 x 0.3 m (please refer to manufacturer for other dimensions and/or quantities).

2 | BUILD

Tubular profiles and fixation accessories as per the Lean modular philosophy (for more information, please refer to the PIBRA® catalogue).



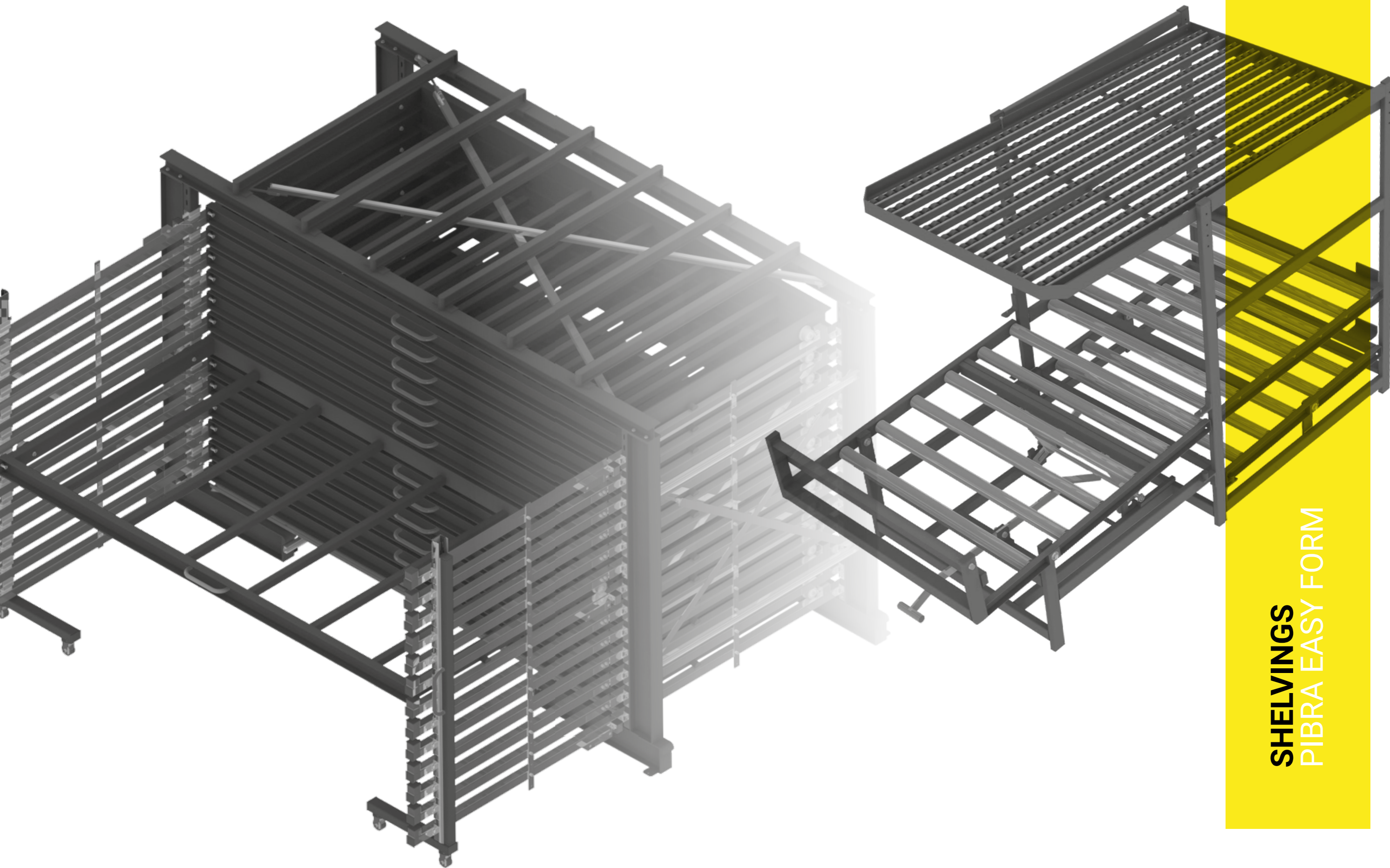

SHELVINGS
PIBRA EASY FORM

PLATE SUPPLY SHELF

The **plate supply shelf** is a metallic structure to drawers, allowing the storage of plate batches in each drawer. This structure aims at a better plate storage, allowing to reduce the occupied area and specific allocation for each plate type.

Its higher structure enables the storage of other materials like iron bars and pipes, this way allowing the occupation of vertical space in the same area.



PLATE SUPPLY SHELF

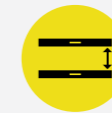
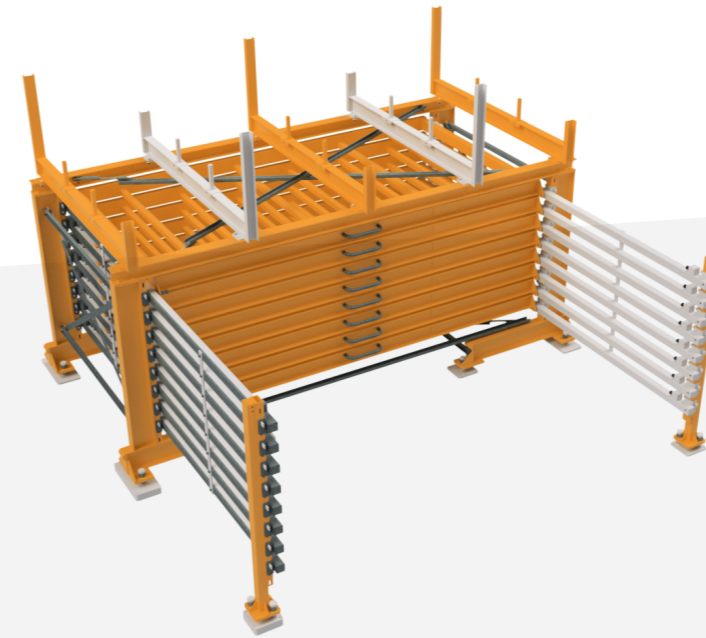

SHELF SPACING

Standard: 75 mm
(Can be made with other dimensions).

GENERAL DIMENSIONS

Please refer to manufacturer for other configurations, dimensions and component quantities.

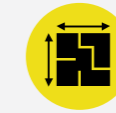

REDUCED APPLICATION AREA

Vertical storage allows decreased space occupation.



RACKS

Wooden or plate racks.

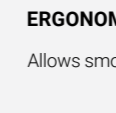

ERGONOMICS

Allows smooth material handling.



HIGHT STORAGE CAPACITY

Vertical storage in layered racks in a small area.



REDUCE ERRORS AND MISTAKES

Segregation and allocation of materials per reference.

PLATE SUPPLY SHELF

This **plate supply shelf** is a metallic structure with drawers, allowing the storage of **plate** batches in each drawer. This structure aims at a better plate storage, allowing to reduce the occupied area and specific allocation for each plate type.

The lock of the drawer supporting structure allows it to occupy a small area when it is not being used, as opposed to the previous shelf.

Vacuum plate handling systems are usually used with this structure.

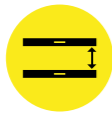
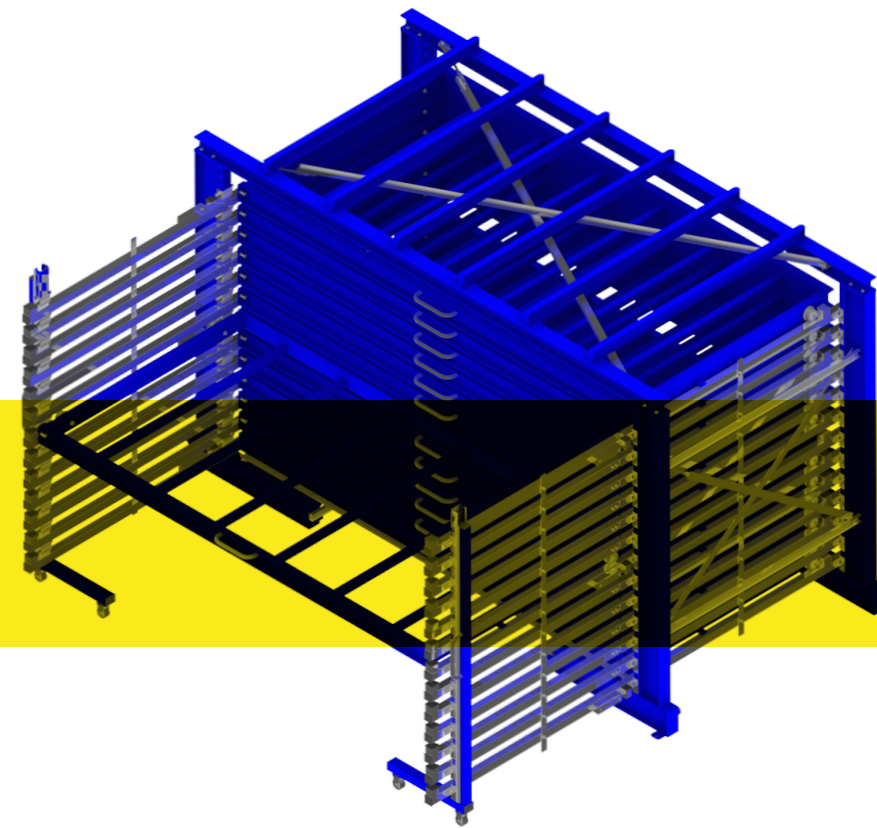

GENERAL DIMENSIONS

Please refer to manufacturer for other configurations, dimensions and component quantities.



REDUCED APPLICATION AREA

Vertical storage allows decreased space occupation.



HIGHT STORAGE CAPACITY

Vertical storage in layered racks in a small area.



SHELF SPACING

Standard: 75 mm
(Can be made with other dimensions).

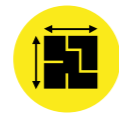

RACKS

Wooden or plate racks.



ERGONOMICS

Allows smooth material handling.



REDUCE ERRORS AND MISTAKES

Segregation and allocation of materials per reference.



SPEEDLOCK

The **Speedlock** is a shelf tailored according to client's specifications. These shelves are a highly reliable and high storage industrial solution. Its adaptability allows the selection of several kinds of pallets and products, and the effective allocation of materials. Its several load capacities and dimensions enable the creation of custom made solutions.

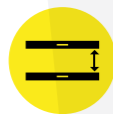
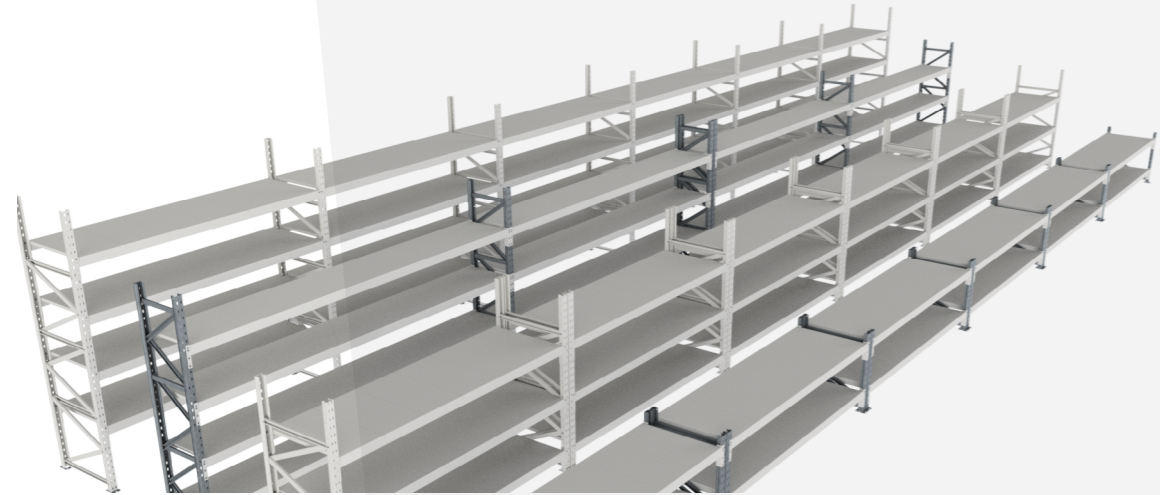

GENERAL DIMENSIONS

Please refer to manufacturer for other configurations, dimensions and component quantities.



REDUCED APPLICATION AREA

Vertical storage allows decreased space occupation.



HIGHT STORAGE CAPACITY

Vertical storage in layered racks in a small area.



SHELF SPACING

Standard: 75 mm
(Can be made with other dimensions).



RACKS

Wooden or plate racks.

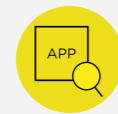

ERGONOMICS

Allows smooth material handling.



REDUCE ERRORS AND MISTAKES

Segregation and allocation of materials per reference.

Application Typology

Traditional Shelves

The most universal system in terms of direct and individual access to each pallet. The ideal solution to warehouses with a great variety of products stored in pallets; Shelf distribution and height are determined depending on forklift, storage elements, and site dimension features.

Advantages

Excellent stock control where each area corresponds to a pallet; Adaptable to any storable cargo dimension, weight or size; Adaptable with manual picking shelves; Double depth shelves can be added to store a higher number of pallets, by allowing to store one pallet front of another on each side of the aisle.

SPEEDLOCK LIGHT

The **Speedlock Light** is a shelf tailored according to client's needs. These shelves are a highly reliable and high storage industrial solution. Its adaptability allows the selection of several kinds of pallets and products, and the effective allocation of materials. Its several load capacities and dimensions enable the creation of custom made solutions.

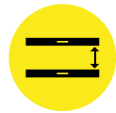

GENERAL DIMENSIONS
According to client specifications.



REDUCED APPLICATION AREA
Vertical storage allows decreased space occupation.



HIGHT STORAGE CAPACITY
Vertical storage in layered racks in a small area.



PROTECTION
Anti-static paint.
(More paint solutions available).

SHELF SPACING
According to client specifications.

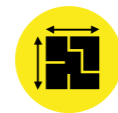

RACKS
Wooden or plate racks.



ERGONOMICS
Allows smooth material handling.



REDUCE ERRORS AND MISTAKES
Segregation and allocation of materials per reference.

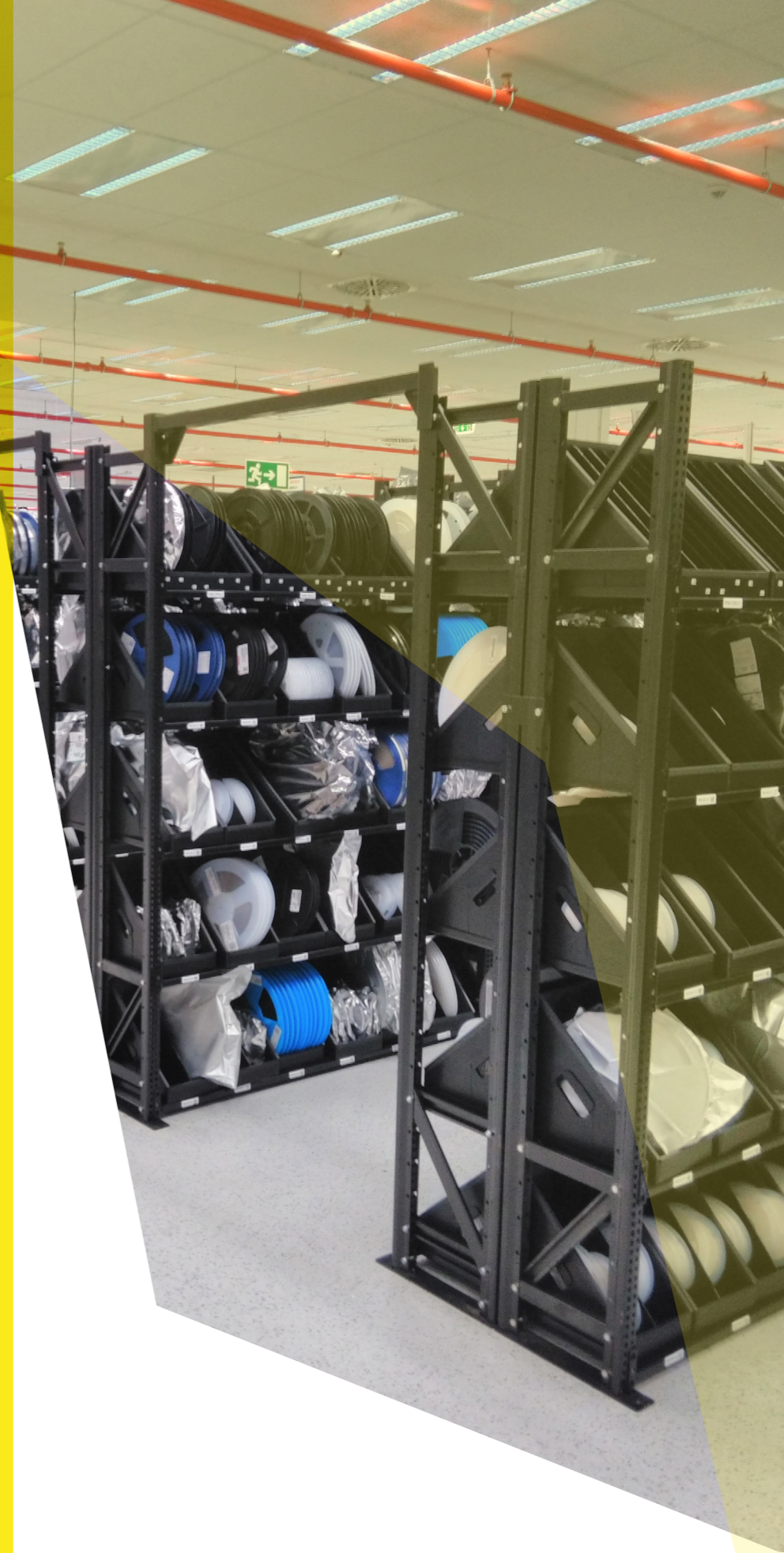

DYNAMIC BOX SHELF

Dynamic box shelf designed for the storage and stock of several products using an inclined rail and roller system, allowing easy access to all components and therefore ensuring the **FIFO (First In, First Out)** system.

Elaborated according to client's needs, these shelves allow the storage of a wide variety of standard boxes or product packages, and can be subsequently adjusted for other uses.

These shelves can be made in the standard format or with insulating components and specific boxes, allowing a high-quality storage with ESD protection.

We create solutions for your needs.

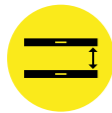

GENERAL DIMENSIONS

According to client specifications.

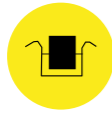

REDUCED APPLICATION AREA

Metalic rails with plastic wheels for box sliding.



HIGHT STORAGE CAPACITY

Vertical storage in layered racks in a small area.



PROTECTION

Anti-static paint.
(More paint solutions available).

SHELF SPACING

According to client specifications.

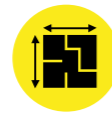

RAILS WITH WHEELS

Metalic rails with plastic wheels for box sliding.



ERGONOMICS

Allows smooth material handling.



REDUCE ERRORS AND MISTAKES

Segregation and allocation of materials per reference.

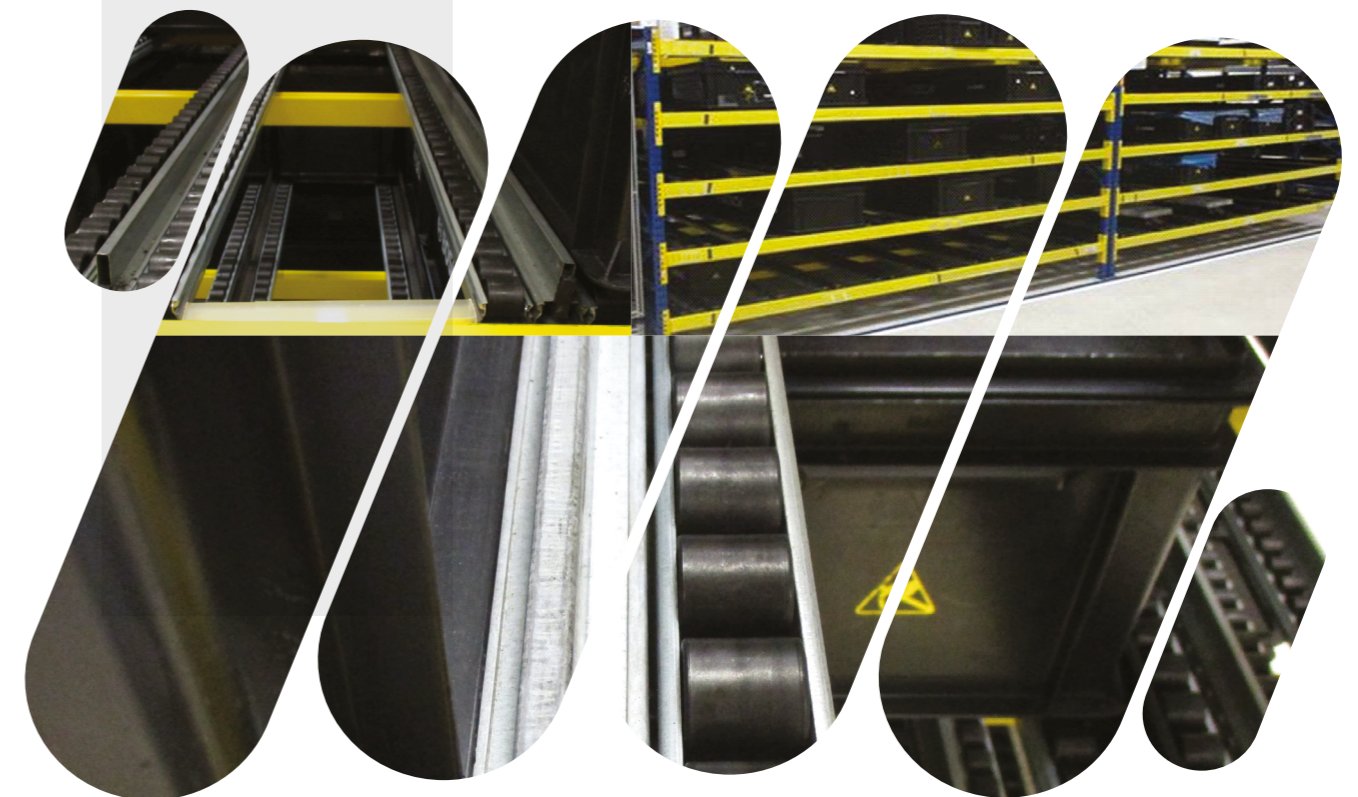

MINI-TRANSTOCKER

The dynamic component storage **Mini-Transtocker** system is based on the FIFO philosophy. With an excellent use of height, it reduces elevated area occupation-related costs. Elevators are activated manually after loading/unloading level selection. In addition to allowing the use of space by means of segregation and sequential order of batches for entry into production, this system can be used with the Transtocker.



GENERAL DIMENSIONS

Please refer to manufacturer for different configurations, dimensions and component quantities.



SHELF SPACING

According to client specifications.

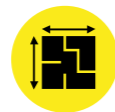



INDUSTRIAL SOLUTIONS

Rua de Pardelhas, nº 87, 4765-420 - Guardizela, Portugal
Tlf: +351 253 479 240 | Fax: +351 253 479 249
info@pibra.com | www.pibra.pt